

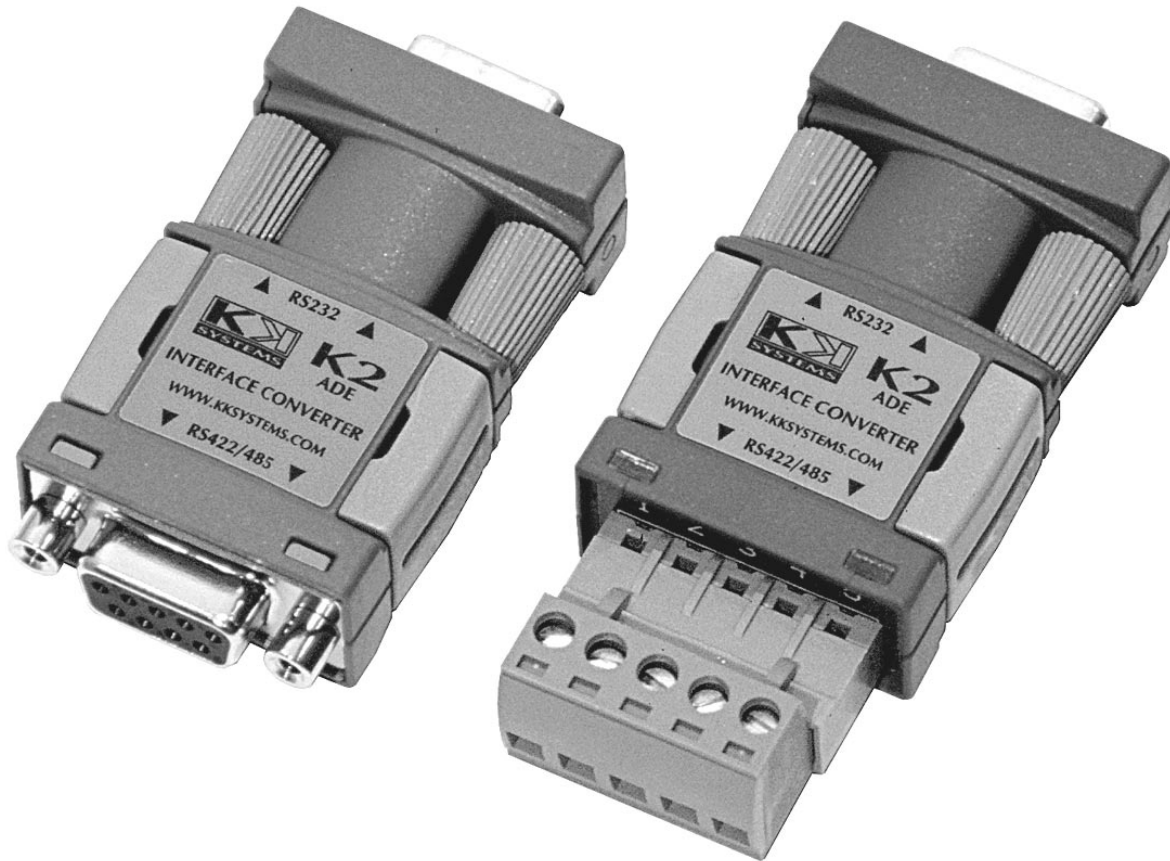

KK SYSTEMS LTD



K2 **RS232-RS422/485 Converter** **K2-ADE** **RS232-RS485 Converter with ADE**

- ✓ Plugs directly into IBM PC 9-way serial port
- ✓ RS232 port-powered in most applications
- ✓ Automatic Driver Enable (ADE) version
- ✓ 400 watt surge protection in ADE version
- ✓ RS232 output swings above and below GND
- ✓ Sony-compatible RS422 pinout
- ✓ Terminal Block (TB) version
- ✓ Very low cost

The K2™ product range is a non-isolated RS232-RS422/485 (2-wire or 4-wire) interface converter for up to 115200 baud.

The **K2** covers RS232-RS422 applications, and RS485 applications where driver control is not required or is provided via the RTS signal.

The **K2-ADE** covers RS232-RS485 applications where automatic driver control is required. A range of baud rates is switch-selectable.

Product Overview

This data sheet covers two products: the K2 and the K2-ADE. Both are based on similar hardware and same package. Both have one RS232 interface and one RS422/485 (2-wire or 4-wire) interface. The 2/4-wire selection and popular variations (e.g. a permanently enabled receiver) are configured with dipswitches and do not need to be specified at time of ordering.

K2 is a general purpose RS232-RS422 (Fig. 1) converter. Can also be used for RS485 (Figs. 2, 3) if driver control is not required (e.g. if used as a Master on a 4-wire 485 system, Fig. 2) or if the RS232 device provides RTS Control (see RTS Control explanation below). The K2 replaces the following older KK products: K422-99, K485-99, K485-99-4W, K485-99-4W-FD, K485-99-FD.

K2-ADE Identical to K2 but with the addition of a microprocessor which enables and disables the 485 driver according to the presence of RS232 data. The K2-ADE is intended for 2-wire RS485 applications (Fig. 3), and for 4-wire RS485 applications (Fig. 2) where the K2-ADE is on the Slave device. However the ADE function can be switched off entirely and then the K2-ADE can be used for RS422 (Fig. 1). The K2-ADE replaces the older K485-ADE product which had a factory-fixed baud rate.

Because the K2-ADE is often used in electrically hostile industrial applications (where an isolated converter, e.g. the K3-ADE, would be more suitable), or is used to drive 2-wire RS485 products on which the ground terminal is missing, the K2-ADE uses large suppression components to clamp the common mode voltage to -1V to +6V (approx.) to help prevent destruction of the converter.

RS422/RS485 Basic Principles

RS422 is full-duplex (data can flow in both directions simultaneously) and is suitable for point-to-point applications only; Fig. 1.

RS485 is half-duplex (data may flow only in one direction at any one time) and exists in two types: **2-wire** (Fig. 3) and **4-wire** (Fig. 2). RS485 systems are always Master/Slave. Each Slave has a unique address and responds only to a correctly addressed message (a "poll") from the Master. A Slave never *initiates* a communication. In a 2-wire system, all devices (including the Master) must have tri-state capability, i.e. its driver can be driving HIGH, LOW or be disabled (open-circuit). In a 4-wire system, the Slaves must have tri-state capability but the Master does not need it (i.e. it can be an RS422 device) because it drives a bus on which all other devices merely listen; this allows an RS422 device to operate as a Master on a 4-wire RS485 bus.

What is RTS Control?

RTS Control is a method with which the RS232 device (typically a PC) tells an RS232-RS485 converter when it should enable its RS485 driver. On low-cost converters this is not done automatically (internally) so an external signal is required. When providing RTS Control, the RS232 device raises its RTS output immediately before it starts to communicate, and drops it after the last bit of the message has been transmitted. The K2 uses this signal to control its RS485 tri-state driver. The K2-ADE does not need this signal because it generates it internally by monitoring the data with a microprocessor.

RTS Control has to be written into the application program and is not an operating system function. Many RS485-oriented application programs have it. Some, particularly under Windows, do not. Also, do not confuse RTS Control with the more common operating mode of the RTS signal which is hardware flow control and which is unsuitable for controlling a 232-485 converter.

Powering the converter from the RS232 port

In this mode, the converter is powered from the RS232 port's RTS and DTR outputs. Historically RS485 supports up to 32 devices on a bus. Since this figure is derived from the drive capability of a standard driver and from the load presented by a standard receiver (input resistance 12 k Ω), some RS485 devices use recently introduced high input resistance receivers to increase this to 128 (using "1/4-load" receivers) or even 256 (using "1/8-load" receivers). The K2 and K2-ADE use an 1/8-load receiver and under ideal conditions could drive a bus with up to 256 similar (i.e. 1/8-load) devices. In practice this cannot usually be achieved because:

- With long cables (e.g. 300m+) cable capacitance is the largest factor in the converter's power consumption, especially at high baud rates. The following table is a very conservative but useful guide for an RS232-port-powered K2 converter. Typical 422/485 twisted pair cables are around 100pF/metre so e.g. 30000pF is around 300m.

Baud Rate (baud)	Max total cable capacitance (pF)	Baud Rate (baud)	Max total cable capacitance (pF)
1200	250000	19200	15000
2400	120000	38400	7500
4800	60000	57600	5000
9600	30000	115200	2500

- The above table is for one standard (12 k Ω) RS422/485 load. For each additional standard load, reduce the cable length by 1/10th, i.e. the maximum recommended number of loads, without using external power, is 10.

- RS232 interfaces vary in their ability to supply power. The K2 draws power from the RS232 interface's DTR signal and, whenever RTS happens to be HIGH, from RTS also. At least one of these must be continuously HIGH to power the converter.
- In some applications the K2 will be driving non-KK devices which usually use "full-load" receivers and then the limit would be 32 devices even with an external power supply.
- Some RS485 systems use termination resistors. An RS232-powered converter will not have enough power to drive these. A capacitor, e.g. 1000pF, can be connected in series with terminators to eliminate this DC loading. However, the controlled slew rate driver used in this converter makes termination unnecessary for cables shorter than approximately 300m.
- At its highest baud rate setting (38400 or 115200 baud) the K2-ADE operates in a different mode internally which increases the power consumption (see Specification). Only desktop PCs with full-power RS232 drivers (e.g. 14C88) are likely to be suitable.

Powering the converter from an external power supply

There is no direct way to tell if the converter is receiving sufficient power from the RS232 device (typically a PC), because there are no spare pins available for this purpose. You need to measure the voltages on the RTS and DTR inputs (pins 7 and 4) while the converter is connected to the RS232 device (this needs a break-out box, or a short cable whose connections can be accessed); whichever of these signals is being used to power the converter must have at least +6V on it (+16V max) during communications.

If the power derived from the RTS and/or DTR signals is insufficient, an external +9V DC or +12V DC power supply can be connected to pin 9 of the RS232 connector as shown in the Connections section. The converter then achieves the full RS422/485 specification of 1200m of twisted-pair cable at 9600 baud, and 32 standard-load devices on the RS485 bus, and terminators can be used if necessary.

👉 The maximum external supply voltage is +16V. Be careful when using cheap unregulated power supply units because a "12V" PSU could rise to 20V or more at the very small load presented by this converter.

Connections

Fig. 1 RS232 to RS422

RTS or DTR (or both) must be HIGH to power the converter

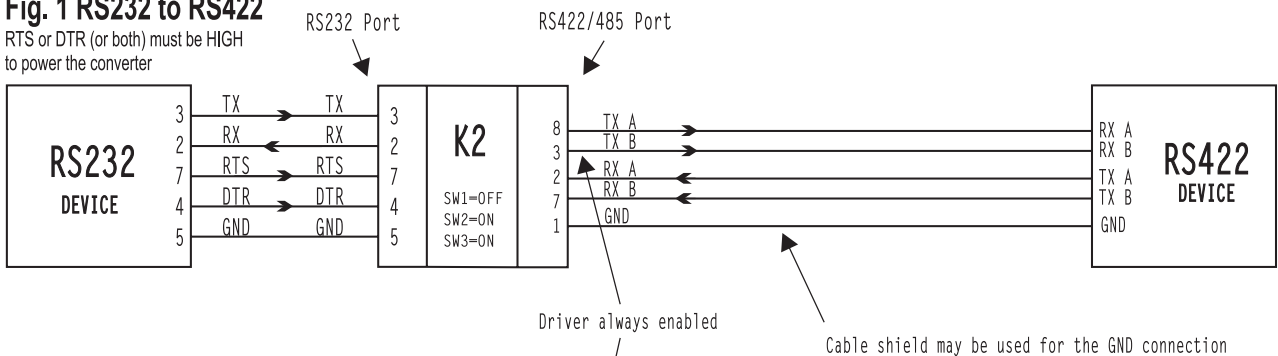

Fig. 2 RS232 to 4-wire RS485

RTS or DTR (or both) must be HIGH to power the converter

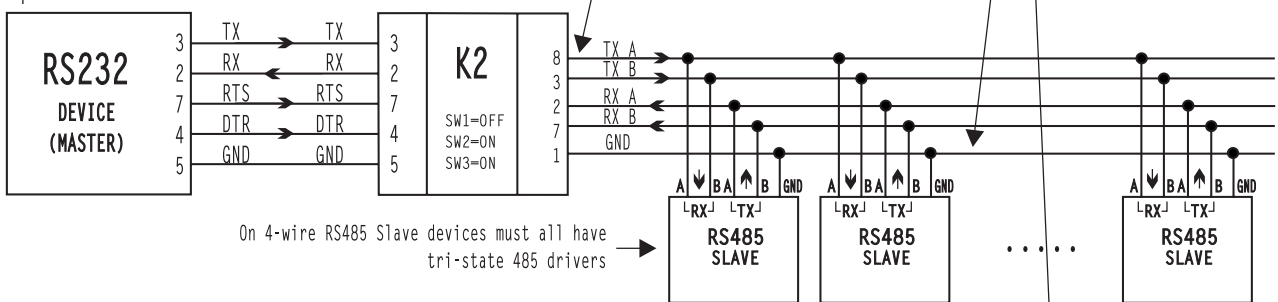
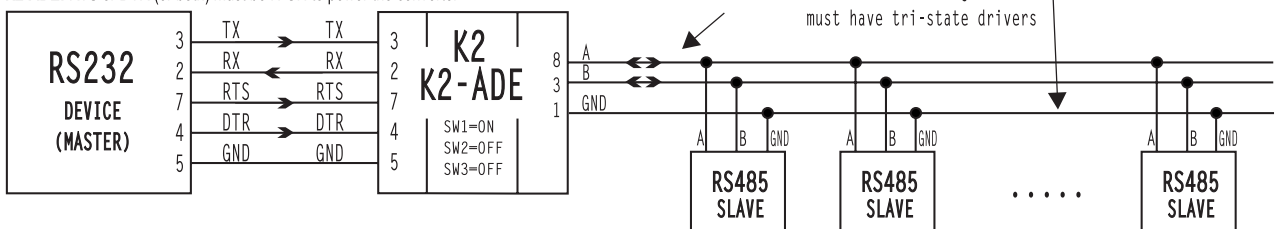

Fig. 3 RS232 to 2-wire RS485

K2: DTR must be HIGH to power the converter; RTS controls RS485 driver
K2-ADE: RTS or DTR (or both) must be HIGH to power the converter



The converter's RS232 port is "DCE" and is designed to plug directly into a standard 9-way IBM PC RS232 port. If your RS232 device's port is 25-way then you need a commonly available 9-25 moulded converter.

A or B: Following RS422/485 standards, the RS422/485 connections above are marked **A** and **B**. They are defined as follows: When the RS232 TX input is at the RS232 HIGH level the A output is at the RS422/485 HIGH level (+5V nominally) and the B output is at the RS422/485 LOW level (0V nominally).

When connecting to other RS422/485 equipment, you may encounter markings such as HI/LO and +/- . Such non-standard markings are unclear and you may need to experiment. Normally, one assumes that the KK converter's A/B corresponds to the other device's A/B, HI/LO or +/- markings respectively but sometimes this is wrong. One simple way to help establish which is which is to measure the voltages on the other product when no communications is taking place: B should be more positive than A.

RX422/485 Grounding: A connection between the converter's GND and the other device(s) interface ground is highly desirable for proper noise immunity. See Figs 1,2,3. The cable shield can be used for this connection. However, unless the other device's interface is isolated (i.e. floating) there is a risk of a ground loop current and this can result in equipment damage. In such a situation the GND connection can be omitted but only if the common mode voltage (the ground potential difference between the two interfaces) is within the standard RS422/485 common mode voltage range of -7V to +12V (-0.5V to +5V for the K2-ADE). If this cannot be guaranteed then an isolated converter should be used instead.

☞ While the K2/K2-ADE replaces the older KK Systems K485-99, the 2-wire RS485 pinouts are not exactly the same! On the K485-99, the "A" signal was on both pins 2,8 and the "B" signal was on both pins 3,7. On the K2/K2-ADE, only pins 8,3 can be used for 2-wire RS485.

Fig. 4 Pin Connections

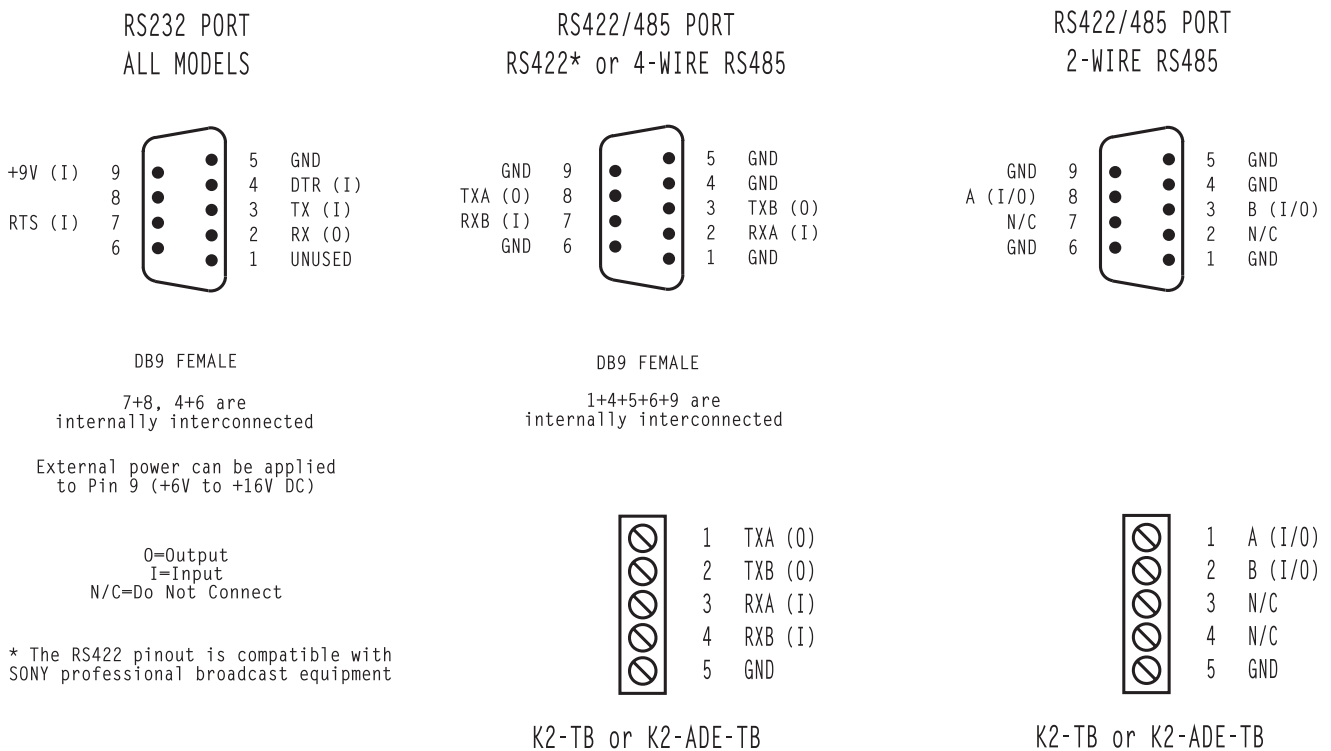

Switch Settings

Fig. 5 Dipswitch Description

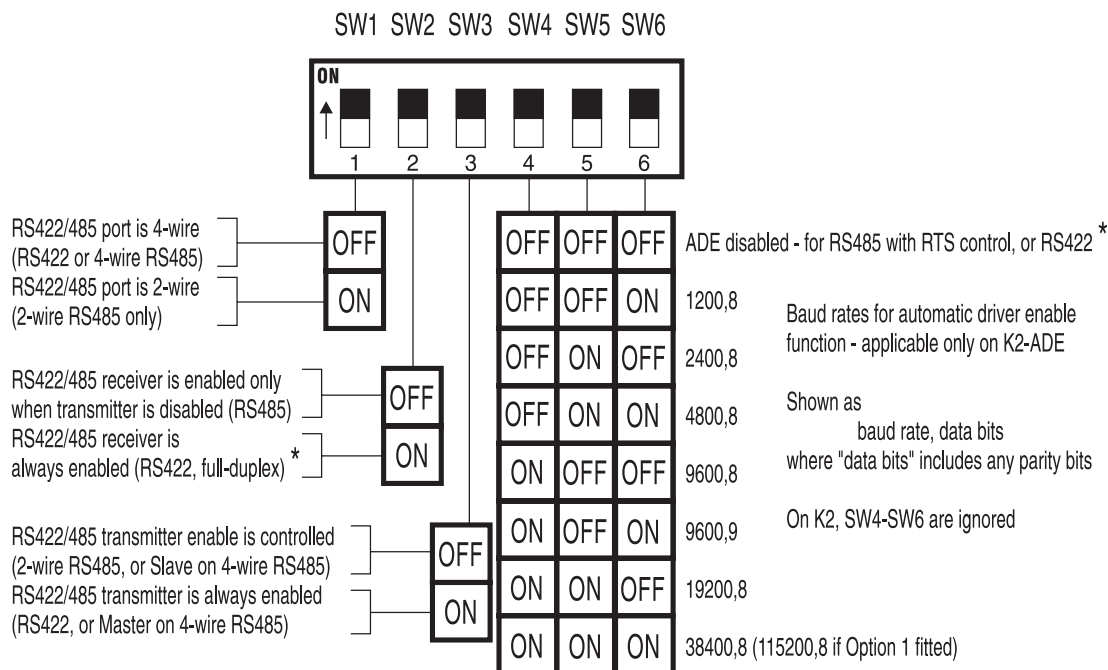

* On K2-ADE, if using it for RS422 (i.e. SW4-SW6=OFF) the following special conditions apply:

SW2 must be OFF

RTS input controls the receiver enable, i.e. for RS422, RTS must be held LOW

Replacing older KK Systems products with the K2 or K2-ADE

	SW1	SW2	SW3
K422-99	OFF	ON	ON
K485-99 / K485-ADE	ON	OFF	OFF
K485-99-FD / K485-ADE-FD	ON	ON	OFF
K485-99-4W / K485-ADE-4W	OFF	OFF	OFF
K485-99-4W-FD / K485-ADE-4W-FD	OFF	ON	OFF

In four-wire applications (i.e. replacing a K422-99, K485-99-4W) the K2 can replace the Kxxx-99 with no cable changes. However, in two-wire applications (i.e. replacing a K485-99) a different cable may be required because the K485-99 had two sets of A/B terminals (which were internally interconnected so either could be used) whereas the K2 has only one set. Consult the respective wiring details for further information.

The K2 has a slightly higher power consumption than the Kxxx-99 but this will be of no consequence because it is still very low.

Troubleshooting

If you cannot establish communications, check the following:

- Check that the RS422/485 A/B connections on the converter are connected to the correct terminals of the other device. Due to commonly non-standard markings on some equipment you may need to experiment by swapping the A/B wires. One simple way to help establish which is which is to measure the voltages on the remote device (with nothing connected to it) when no communications are taking place: B should be more positive than A.
- Check that the converter is receiving an adequate supply from the RS232 RTS, DTR signals. You need to measure the voltages on the RTS and DTR inputs (pins 7 and 4) while the converter is connected to the RS232 device (this needs a break-out box, or a short cable whose connections can be accessed); whichever of these signals is being used to power the converter must have at least +6V on it during communications.

- Check that any termination resistors are removed, or have a series capacitor; see the Power Considerations section.
- Ensure that the grounding instructions are followed; see the Connections section.
- If driver control is required (true for all 2-wire RS485 applications, and for Slave 4-wire RS485 applications) then check that your RS232 device is providing the correct type of RTS Control (see the What is RTS Control section). In the IBM PC (DOS or Windows) context, the application program must be specifically written to manipulate RTS - this is not an operating system function which you can simply configure. Alternatively, use the K2-ADE.

Specification

Serial parameters: K2: 0-115200 baud, any character format including break levels.
 K2-ADE: 1200, 2400, 4800, 9600, 19200, 38400/115200* (8 data bits, or 7 bits plus parity); 9600 (8 bits plus parity). Any number of stop bits. Break levels supported.
 * 38400 baud on standard unit, Option 01 replaces 38400 baud with 115200 baud

RS232 interface: RX threshold +1.5V typ. Hysteresis 500mV typ. RX Zin 5k Ω typ. TX output swing \pm 4V typ. into 3k Ω load.

RS422/485 i/face: RX threshold 200mV typ (differential). Hysteresis 50mV typ. RX Zin 96k Ω min.
 TX output swing 5V (no DC load); 1.5V (60 Ω load, applies with external power only).
 Maximum common-mode voltage -7V to +12V (K2); -0.5V to +5V (K2-ADE).

Supply current: All following figures are typical, with one standard 12k Ω load and no significant cable load:
 K2: 2mA (all baud rates)
 K2-ADE: 3.5mA (1200-9600 baud); 5mA (19200 baud); 7mA (38400/115200 baud)

Environmental: Operating 0 to +50C, storage -40V to +70C, RH 0 to 90% non-condensing

CE compliance: Emissions EN50081-2, immunity EN50082-2

Dimensions: 34mm (W) x 17mm (H) x 62mm (L)

Ordering Information

K2 RS232-RS422/RS485, requires RTS control for all 2-wire and Slave 4-wire applications

K2-TB Terminal block version of the above

K2-ADE As K2, adds automatic driver enable, 1200-38400 baud

K2-ADE-TB Terminal block version of the above

K2-ADE-OPT01 As K2-ADE, 38400 baud switch setting is replaced with 115200 baud

Other products designed and manufactured by KK Systems

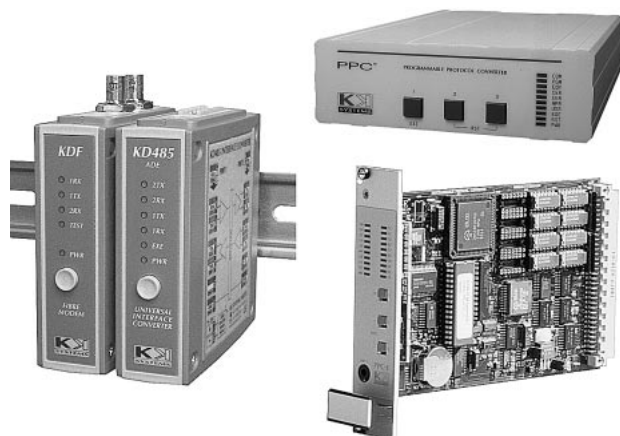

A range of high quality low cost RS232-RS422, RS485, 20mA and fibre interface and protocol converters is also available in both inline and DIN rail packages, with and without isolation.

Please contact us or see our website for details.



Designed and Manufactured by:



KK Systems Ltd
 Tates, London Road
 Pyecombe, Brighton
 BN45 7ED
 Great Britain

☎ +44 (0) 1273 857185
 fax +44 (0) 1273 857186
 e-mail info@kksystems.com
 www www.kksystems.com