

BIALON PC 05

400 V phase coupler for transmission on LONWORKS® **Power Line** networks



- Couples the payload signal into the 230 V power network (L-N) or 400 V power network (L-L)
- Increases capacitive coupling between the phases
- Reduces the signal attenuation in case of transmission over multiple phases
- The payload signal can be coupled and decoupled for zero-power transmission
- Potential isolation between input and output
- Easy installation on a top-hat rail

The BIALON PC 05 phase coupler is a critical infrastructure component for safe data transmission on LONWORKS® Power Line networks. In contrast to the PC 02 single-phase coupler, the input circuitry on the BIALON PC 05 is designed for 400 V AC. This makes it possible to couple the Power Line signal between two phase conductors (L-L; conductor-conductor) with a voltage of 400 V.

The phase coupler helps to improve capacitive coupling between the phases of the AC network. It helps to establish a communication link across all three phases. Its use is necessary when the transmission between the phases is not sufficient for communication due to cable routing. Additionally, the phase coupler is used to communicate across residual current circuit breakers, meter circuits or transformer stations.

It is installed on a DIN top-hat rail in the distribution box.

Order details

Description	Order number
BIALON phase coupler PC 05	095023

Typical applications:

In addition to coupling the phases in a three phase system or two separate power circuits via an "unpowered" wire-pair connection, the PC 05 phase coupler can also be used to couple a Power Line signal from a PC slot card, a Power Line router or a USB adapter without their own internal phase coupler.

In contrast to the PC 02 single-phase coupler, the PC 05 phase coupler also couples the Power Line signal between two phases of a 3-phase current system with a voltage of 400 V.

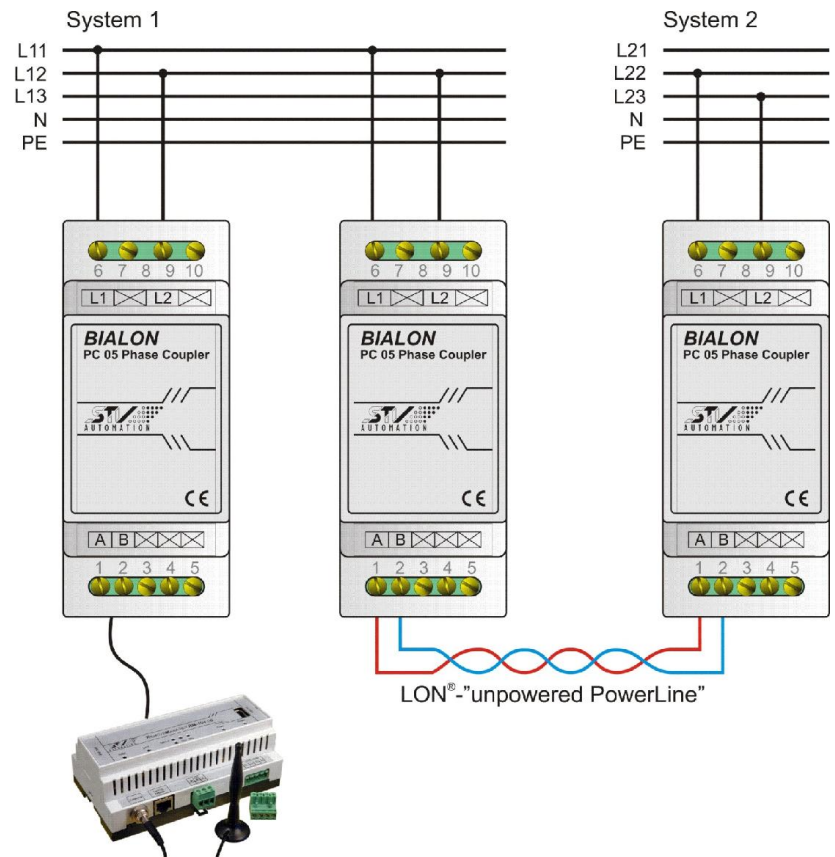

Technical data

Phase/phase voltage	max. 380 V \pm 10%
Rated frequency	50 Hz
Connection phase	Terminals max. 2.5 mm ²
Neutral cable connection	Terminals max. 2.5 mm ²
LON [®] connection	Terminals max. 2.5 mm ²
Operating temperature	0 ... 55 °C
Relative humidity	0 ... 90 % (not condensing)
Housing	as per EN 50022 for installation on DIN support channels, 2 separation units,
Degree of protection	IP 20 as per DIN EN 60529
Dimensions (L x W x H)	36 x 90 x 66 mm (2 SU)